



Flake Ice generator G100 - PREMIUM RANGE

FLAKE ICE GENERATOR G100 - PREMIUM + RANGE

DAILY ICE PRODUCTION	REFRIGERANT	WATER TEMPERATURE	EVAP. T°	REFRIGERATING CAPACITY
2500 kg / 24 h	NH3 - FREON - CO ²	15 °C	-27 °C	14 KW

REAMER SPEED	ICE THICKNESS	REFRIGERANT CHARGE	OVERALL DIMENSIONS L X W X H	NET WEIGHT
128 tr/h	1,7 mm	2 kg	682 x 635 x 1066 mm	160 kg

DESCRIPTION	ELECTRICAL CONNECTIONS POWER SUPPLY	NOMINAL POWER	AMPERAGE
Reamer motor	400 V - 3 - 50 Hz	1 x 180 W	1 x 0,8 A
Pump	230 V - 1 - 50 Hz	1 X 70 W	1 x 0,3 A
Torque limiter switch	-	-	-

OPTIONS

- Electrical control panel
- Ice level detector
- Remote control
- Salt dosing pump

- *Stainless steel cylinder*
- *Stainless steel water path*
- *Reduced refrigerant charge*
- *Reduced weight*
- *Availability with a maximum working pressure of 40 bar for CO₂*
- *Availability for natural refrigerants (CO₂, NH₃)*
- *PED & ASME compliant*

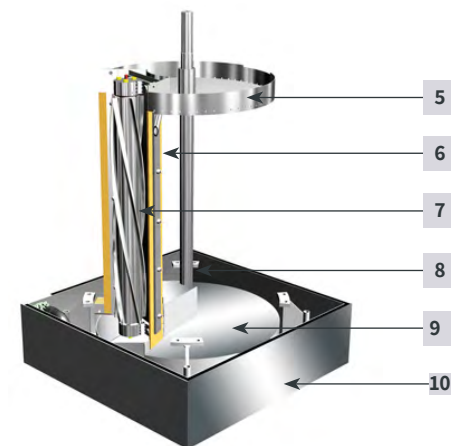
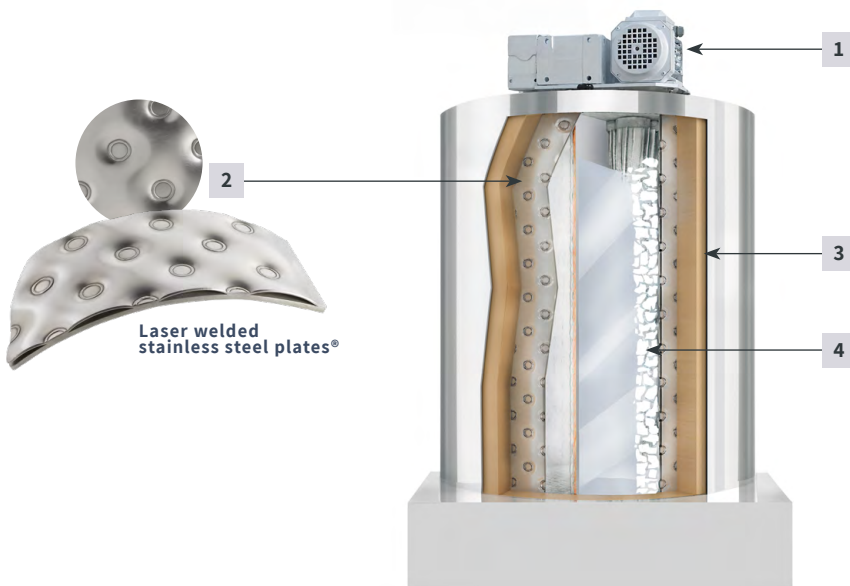

DRIVE FOR REVOLVING PART

- 1 Gear reducer & torque limiter

CYLINDER

- 2 **Stainless steel** stationary cylinder (Laser welded stainless steel plates®, patented process)
- 3 **Stainless steel** liner with injected insulation
- 4 **Dry and sub-cooled flake ice**

REVOLVING PART

- 5 **Stainless steel** upper water distribution tray
- 6 **Stainless steel** vertical deflector for rubber wiper
- 7 **Stainless steel** helical reamer
- 8 **Stainless steel** revolving central shaft
- 9 **Stainless steel** lower water collection tray
- 10 **Stainless steel** insulated base

REFRIGERATING PART

- Heat exchanger-suction line
- Thermostatic expansion valve



Geneglace SAS

9 rue des Orfèvres - 44840 Les Sorinières (France)
 Tel.: +33 (0)2 51 19 10 51 - Fax : +33 (0)2 40 05 73 81
 www.geneglace.com - contact@geneglace.com